

ΕΞΑΕΡΙΣΤΗΡΕΣ ΑΕΡΑΓΩΓΩΝ ΚΥΚΛΙΚΗΣ ΔΙΑΤΟΜΗΣ ΑΝΤΙΕΚΡΗΚΤΙΚΟΥ ΤΥΠΟΥ

ΣΕΙΡΑ TD-ATEX



IN LINE FLOW DUCT FANS EXPLOSION PROOF MOTOR

- Κατασκευή από αντιστατικό πλαστικό υλικό.
- Μοτέρ **230V-50Hz**, IP: 44, Κλάση B.
- Για θερμοκρασίες λειτουργίας από -20°C - $+40^{\circ}\text{C}$



MODEL - 800

II2G EExell T3
EC-type Examination Certificate
nr. LOM 08ATEX2052 X

MODEL - 1100 - 1200

II2G EExell T3 Gb
nr. LOM 11ATEX2021 X Supplement

ΤΥΠΟΣ	ΣΤΡΟΦΕΣ rpm	WATT	AMBER	ΠΑΡΟΧΗ m ³ /h	dB (A)	ΔΙΑΜΕΤΡΟΣ Ømm	ΒΑΡΟΣ (Kg)
TD - 800/200 EX	2450	130	0,54	1020	44	200	5
TD - 1100/250 EX	2630	197	0,81	1130	46	250	20
TD - 1200/315 EX	2600	170	0,71	1320	44	315	25

ΚΑΜΠΥΛΕΣ (mm)

CURVES (mm)

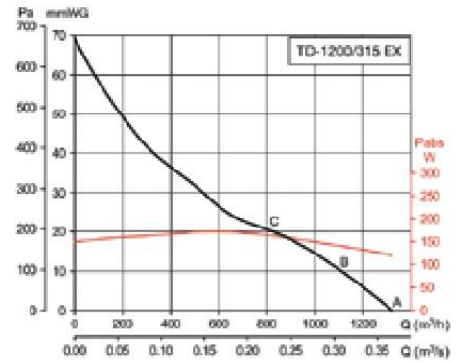
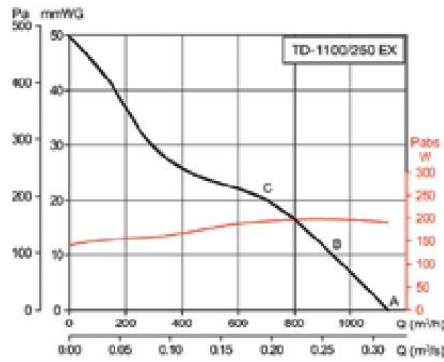
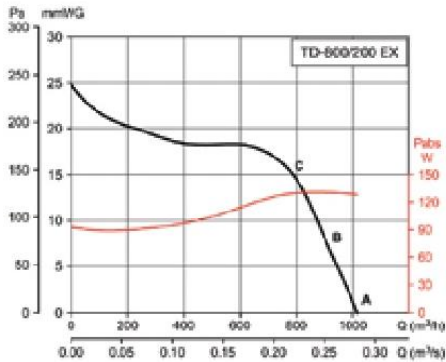

ΔΙΑΣΤΑΣΕΙΣ (mm)

DIMENSIONS (mm)

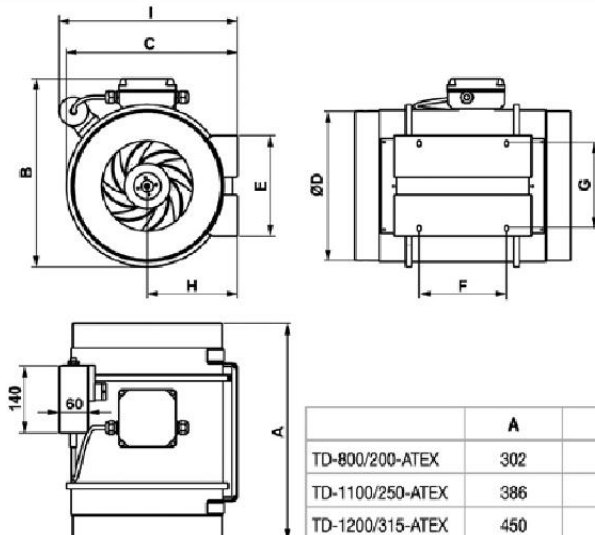

	A	B	C	Ø D	E	F	G	H	I
TD-800/200-ATEX	302	255	232,5	198	140	100	94	124	228,4
TD-1100/250-ATEX	386	324	291	248	168	145	140	155	339
TD-1200/315-ATEX	450	392	356	312	210	182	178	188	371